

# SA3-014M & SA3-014M/E



**iNELS**



EN Switching actuator, 14 channels

02-57/2023 Rev.0

## Characteristics

- SA3-014M is a switching actuator containing 14 independent relays with NO potentialless contacts, with the fact that switches the same potential. Maximal loadability of contacts is 10A/2500 VA/AC1.
- Each of the fourteen output contacts are individually controllable and addressable.
- Actuator SA3-014M is powered by an bus voltage 27V DC.
- The unit's status is indicated by the green RUN LED on the front panel
  - if the bus supply is connected, but there is no communication via BUS with master, the LED RUN is on continuously.
  - if the bus voltage is connected and the unit communicates by BUS, the LED RUN flashes.
- LED output indication on the front panel signals the status of each output. Contact status of each relay can be changed separately and manually by control buttons on a front panel. (only SA3-014M)
- The unit has synchronized closing and opening of the relay in the zerovoltage of the sinusoidal waveform. The sync inputs are COM 1, 3, 5, 7, 9, 11 and 13 against the N terminal.
- SA3-014M is normally supplied in the option AgSnO2 contact material. SA3-014M in design 6-MODULE is designed to be mounted into a switchboard, on to DIN rail EN60715.
- SA3-014M/E is an economic option without manual control buttons on the front panel and status LEDs for the relay output. (possibility to control via iDM software).

## Description of device

### SA3-014M

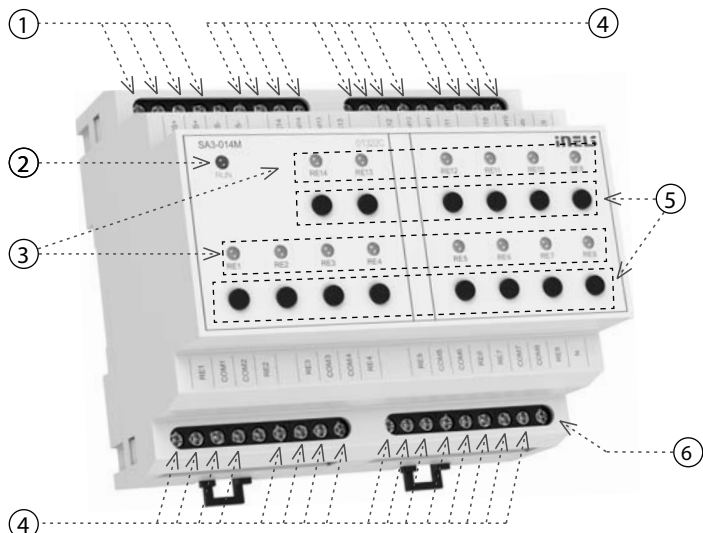

### SA3-014M/E

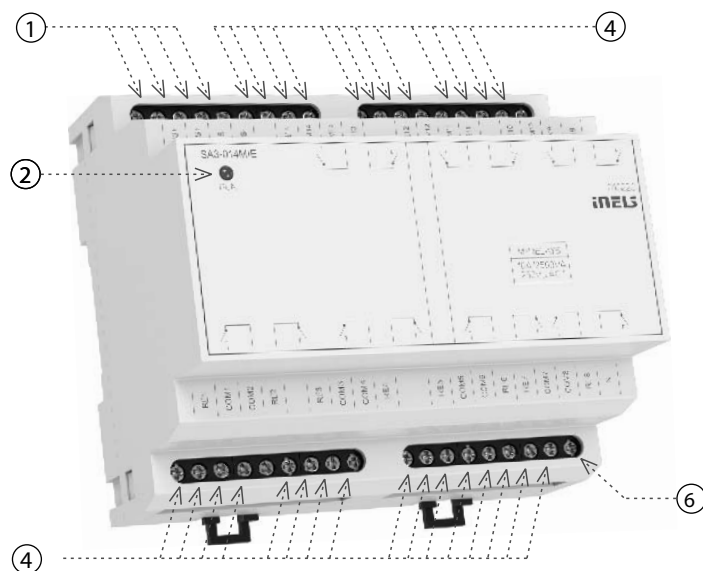

1. Data BUS
2. LED indication of unit's state
3. LED output indication
4. Relay contacts
5. Control buttons
6. Input for phase synchronization

## Connection

### SA3-014M & SA3-014M/E

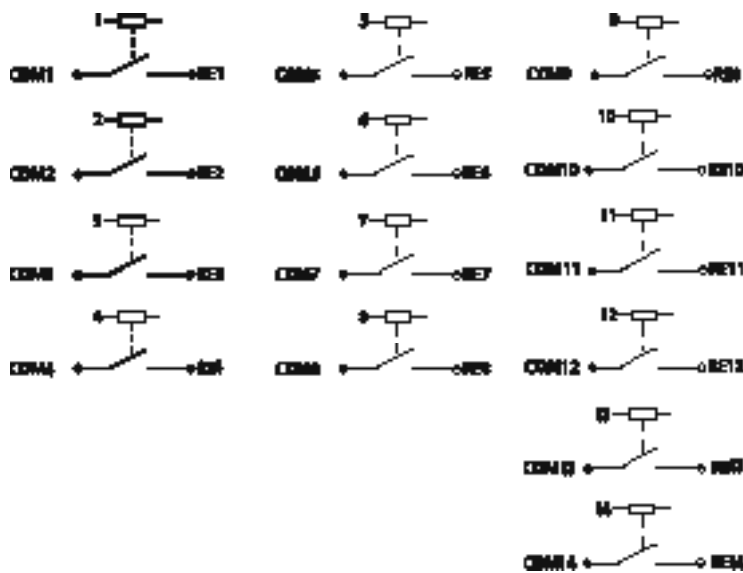
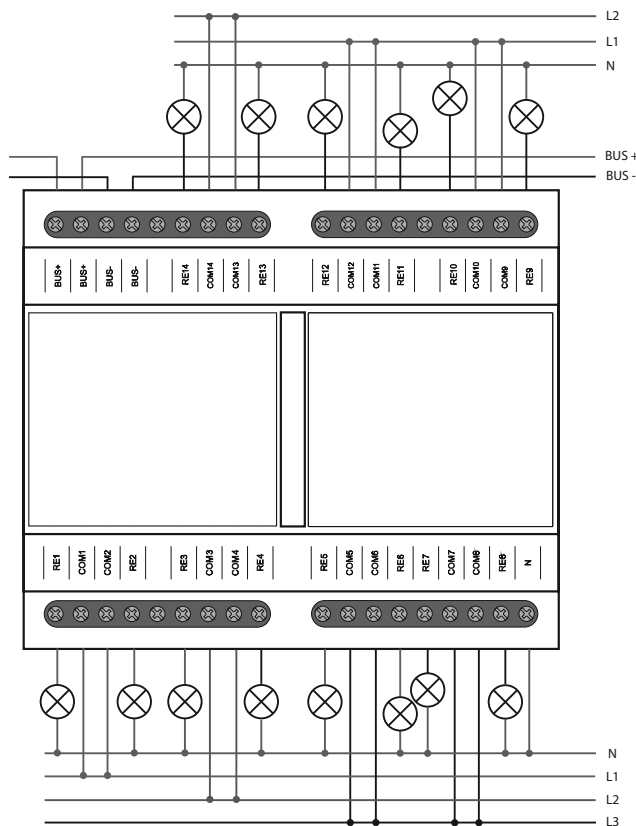

**SA3-014M SA3-014M/E**

<b>Outputs</b>	
Output:	14x switching 10 A/AC1
Switched voltage:	250 V AC, 30 V DC
Switched output:	2500 VA/AC, 150 W/DC
Peak current:	10 A
Pre-assigned protection of the relay contact:	10A circuit breaker with tripping characteristic B
Output relays separated from all internal circuits:	reinforced insulation (Cat. II surges by EN 60664-1)
Isolation between relay outputs COM 1,2 COM 3,4 COM 5,6 COM 7,8 COM 9,10 COM 11,12:	reinforced insulation (Cat. II surges by EN 60664-1)
Isolates. voltage open relay contact:	1 kV
Max. current of one common terminal:	12 A
Minimal switched current:	100 mA/10 V DC
Switching frequency without load:	300 min <sup>-1</sup>
Switching frequency with rated load:	15 min <sup>-1</sup>
Mechanical life:	1x 10 <sup>7</sup>
Electrical life AC1:	1x 10 <sup>5</sup>
Mains voltage detection:	yes (relay switching in zero)
Output indication:	14x yellow LED
Control:	14x buttons front panel
<b>Communication</b>	
Installation BUS:	BUS
Status indication unit:	green LED RUN - status led for relay   only RUN LED
<b>Power supply</b>	
Voltage of BUS/tolerance/nominal current:	27 V DC, -20/+10 %, 150 mA
<b>Connection</b>	
Terminal:	max. 2.5 mm <sup>2</sup> /1.5 mm <sup>2</sup> with sleeve
<b>Operating conditions</b>	
Operating temperature:	-20 to +55 °C
Storing temperature:	-30 to +70 °C
Protection degree:	IP20 device, IP40 mounting in the switchboard
Overvoltage category:	II.
Pollution degree:	2
Operating position:	any
Installation:	switchboard on DIN rail EN 60715
Design:	6-MODULE
<b>Dimensions and weight</b>	
Dimensions:	90 x 105 x 65 mm
Weight:	310 g

**CONNECTION TO THE SYSTEM, INSTALLATION BUS**

iNELS3 peripheral units are connected to the system through the BUS installation. Installation BUS conductors are connected to the terminal units to BUS+ and BUS- terminals, wires cannot be interchanged. For installation of BUS it is necessary to use a cable with a twisted pair of wires with a diameter of at least 0.8 mm, the recommended cable is iNELS BUS Cable, whose features best meet the requirements of the BUS installation. Bearing in mind that in terms of all the properties it is possible in most cases also use the cable JYSTY 1x2x0.8 or JYSTY 2x2x0.8, however it is not recommended as the best option. In the case of a cable with two pairs of twisted wires it is not possible to use the second pair of the other for modulated signal due to the speed of communications; it is not possible within one cable to use one pair for one segment BUS and the second pair for the second segment BUS. For installation of BUS it is vital to ensure that it is kept at a distance from the power lines of at least 30 cm and must be installed in accordance with its mechanical properties. To increase mechanical resistance of cables we recommend installation into a conduit of suitable diameter. BUS topology installation is free except for the ring, wherein each end of the bus must terminate at the terminals BUS+ and BUS- peripheral unit. While maintaining all the above requirements, the maximum length of one segment of the installation BUS can reach up to 300 m. Due to the data communication and supply of units in one pair of wires, it is necessary to keep in mind the diameter of wires with regards to voltage loss on the lead and the maximum current drawn. The maximum length of the BUS applies provided that they comply with the tolerance of the supply voltage.

**CAPACITY AND CENTRAL UNIT**

It is possible to connect to the central unit CU3-01M/02M or miniCU CU3-07/08/09/10M independent BUSes by means of terminals BUS1+, BUS1- or BUS2+, BUS2-. It is possible to connect to each BUS up to 32 units, so it is possible to connect directly to the central unit a total of 64 units. It is necessary to comply with the requirement of a maximum load of one BUS line - maximum up to 1000 mA current. When connecting units which draw greater than 1A, BPS3-01M with 3A sampling can be used. It is the sum of the rated currents of the units connected to the BUS line, other units can be connected using the units MI3-02M (for CU3-01M/02M), which generate further BUSes. These are connected to the CU3-01M/02M unit via the system BUS EBM and you can connect a total of 8 units via EBM BUS to the central unit MI3-02M.

**SUPPLYING THE SYSTEM**

For supplying power to system units, it is recommended to use the power source of ELKO EP titled PSM3-30/iNELS, PSM3-60/iNELS, PSM3-100/iNELS or PS3-30/iNELS. We recommend backing up the system with backup batteries.

**GENERAL INFORMATION**

To operate the unit, it is necessary that the unit is connected to a central unit CU3 series, connected to the central unit of the system CU3, or to a system that already contains this unit as its expansion to include further system. All unit parameters are set through the central unit CU3-0XM in the software iDM3. There is LED diode on the PCB for indication of supply voltage and communication with the central unit series CU3. In case that the RUN diode flashes at regular intervals, so there is standard communication between the unit and BUS. If the RUN diode lights permanently, so the unit is supplied from BUS, but there is no communication between BUS and unit. In case that RUN diode is OFF, so there is no supply voltage on the terminals BUS+ and BUS-.

**Warning**

Before the device is installed and operated, read this instruction manual carefully and with full understanding and Installation Guide System iNELS3. The instruction manual is designated for mounting the device and for the user of such device. It has to be attached to electro-installation documentation. The instruction manual can be also found on a web site [www.inels.com](http://www.inels.com). Attention, danger of injury by electrical current! Mounting and connection can be done only by a professional with an adequate electrical qualification, and all has to be done while observing valid regulations. Do not touch parts of the device that are energized. Danger of life-threat! While mounting, servicing, executing any changes, and repairing it is essential to observe safety regulations, norms, directives and special regulations for working with electrical equipment. Before you start working with the device, it is essential to have all wires, connected parts, and terminals de-energized. This instruction manual contains only general directions which need to be applied in a particular installation. In the course of inspections and maintenance, always check (while de-energized) if terminals are tightened.